

Overview

- Provides 3 additional control wires and a common connection 'C' between a thermostat and indoor unit.
- The Model 5000 cannot add wiring between an indoor and outdoor unit for air conditioner or heat pump installations.
- Compatible with most 24VAC heating and cooling systems.

Electrical Safety

- This product should only be installed by a qualified technician.
- Requires a Class 2 transformer providing 23-28VAC.
- The total connected load must not exceed 2 amps.
- The connected load cannot operate at more than 30VAC (not designed for direct connection to 120VAC equipment).
- To avoid risk of electrical shock or equipment damage, disconnect power before beginning installation.

Sender Installation

The Sender is the smaller component and is installed inside the wall behind the thermostat.

- Remove the thermostat from the wall.
- If the hole where the thermostat cable wires come through is not big enough to fit the Sender, enlarge it.
- Place the Sender in the wall and connect the wires to the sub-base according to the wiring diagram (pages 3-4). The Sender will hang by its wires and does not require any mounting.
- Install the thermostat on the wall.

Note: The Sender will produce a small amount of heat while operating. Install the Sender at least 8" (20cm) away from the thermostat. Do not install the Sender in insulated walls.

Receiver Installation

The Receiver is the larger component and is installed inside the cabinet of the indoor unit. If there is no space inside the cabinet, the Receiver may be placed in any location without exposure to high temperatures or water.

Connect the Receiver according to the wiring diagram for the system (pages 3-4).

If the installation only has single stage heat, only the Sender and Receiver's white wire will be used. The blue wire from the Sender and Receiver should be taped back.

Some installations may require the Receiver voltage to be adjusted. See 'Setting the Receiver Voltage' for more information.

The Orange Wire

The Receiver's orange wire is only used for setting the Receiver voltage. In most installations, the orange wire will not be used. After the Model 5000 is installed and working correctly, the orange wire should be taped back as it is no longer needed.

Setting the Receiver Voltage

The Model 5000 is factory set to be compatible with most thermostats.

Differences in transformer voltage and thermostat power consumption may require the Receiver to be adjusted. The adjuster is located on the side of the case and can be turned to increase or decrease the Receiver voltage.

The voltage (DC) of the Receiver is measured between the Receiver's orange wire and transformer Common. It is factory set for approximately 0.30V (with a 24VAC transformer) while disconnected from the thermostat. When connected to a typical thermostat in standby, the voltage should be between 0.40V to 0.50V.

Check each function on the thermostat (G, Y, W1, W2) to see if the connected equipment turns on and off correctly.

If the equipment does not turn on when called, the Receiver voltage may be too low. With the thermostat calling for any function, increase the Receiver voltage until the equipment activates. Set the voltage to 0.05V over the minimum voltage the equipment activates at.

If the equipment does not turn off when the thermostat stops calling, the Receiver voltage is too high. With the thermostat not calling for any function, decrease the Receiver voltage until the equipment turns off.

After the Receiver voltage has been set, check that all equipment turns on and off correctly.

Operation

The Model 5000 has two channels, green and yellow, and white and blue.

Applying 24VAC to the Sender's green wire will output 24VAC on the Receiver's green wire.

Applying 24VAC to the Sender's green and yellow wires will output 24VAC on the Receiver's green and yellow wires.

Applying 24VAC to the Sender's white wire will output 24VAC on the Receiver's white wire.

Applying 24VAC to the Sender's white and blue wires will output 24VAC on the Receiver's white and blue wires.

While 24VAC is applied to the Sender's white or blue wires, the yellow and green wires at the Receiver will not output 24VAC regardless of whether or not they are being called.

Contact Us

For installation assistance, our technical support line can be reached at 1-800-775-4750, 9am-5pm PST, or emailed at info@nordictech.ca



E506697 - Purpose of Control: Operating Control, Construction of Control: Independently Mounted, Type 1 Action, Pollution Degree 2, Impulse Voltage: 330V

Troubleshooting

1. Measure the transformer voltage to check if it drops below 23VAC while in use. The Model 5000 may not function properly outside of the 23-28VAC range and the transformer may need to be replaced.
2. If applying 24VAC to 'G' on the Sender activates 'W1' on the Receiver, or vice versa, then the two wires that connect the Sender and Receiver are crossed. Disconnect the thermostat cable and swap the connections.
3. At the thermostat, jumper 'R' to 'G' to activate the fan. Jumper 'R', 'G', and 'Y' to activate the fan and condenser. Jumper 'R' to 'W1' to activate first stage heat. Jumper 'R', 'W1', and 'W2' to activate second stage heat. If all functions work correctly when jumpered, then the thermostat may not be configured properly. If no functions operate there may be a break in the thermostat cable.
4. If the Receiver is set to the highest voltage possible and still does not activate the equipment when called, then the power consumption of the thermostat may be too low. Please contact our technical support line at 1-800-775-4750.

Incompatible Thermostats

The Model 5000 cannot provide a common 'C' connection to the following thermostats:

- Honeywell T1 Pro TH1110D2009
- Honeywell T4 Pro TH4110U2005
- Honeywell T6 Pro TH6210U2001
- Honeywell T6 Pro TH6320U2008

If the thermostat runs on batteries with the 'C' wire disconnected, the remaining functions (G, Y, W1, W2) of the Model 5000 can still be used.

A Thermostat Cable with Two or More Wires

Before

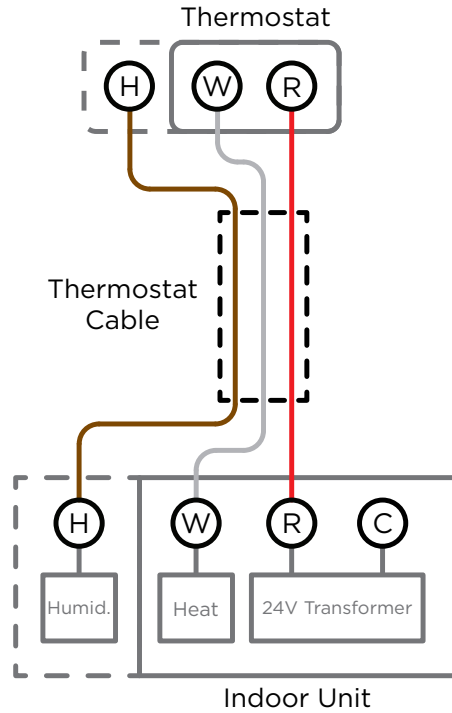

After

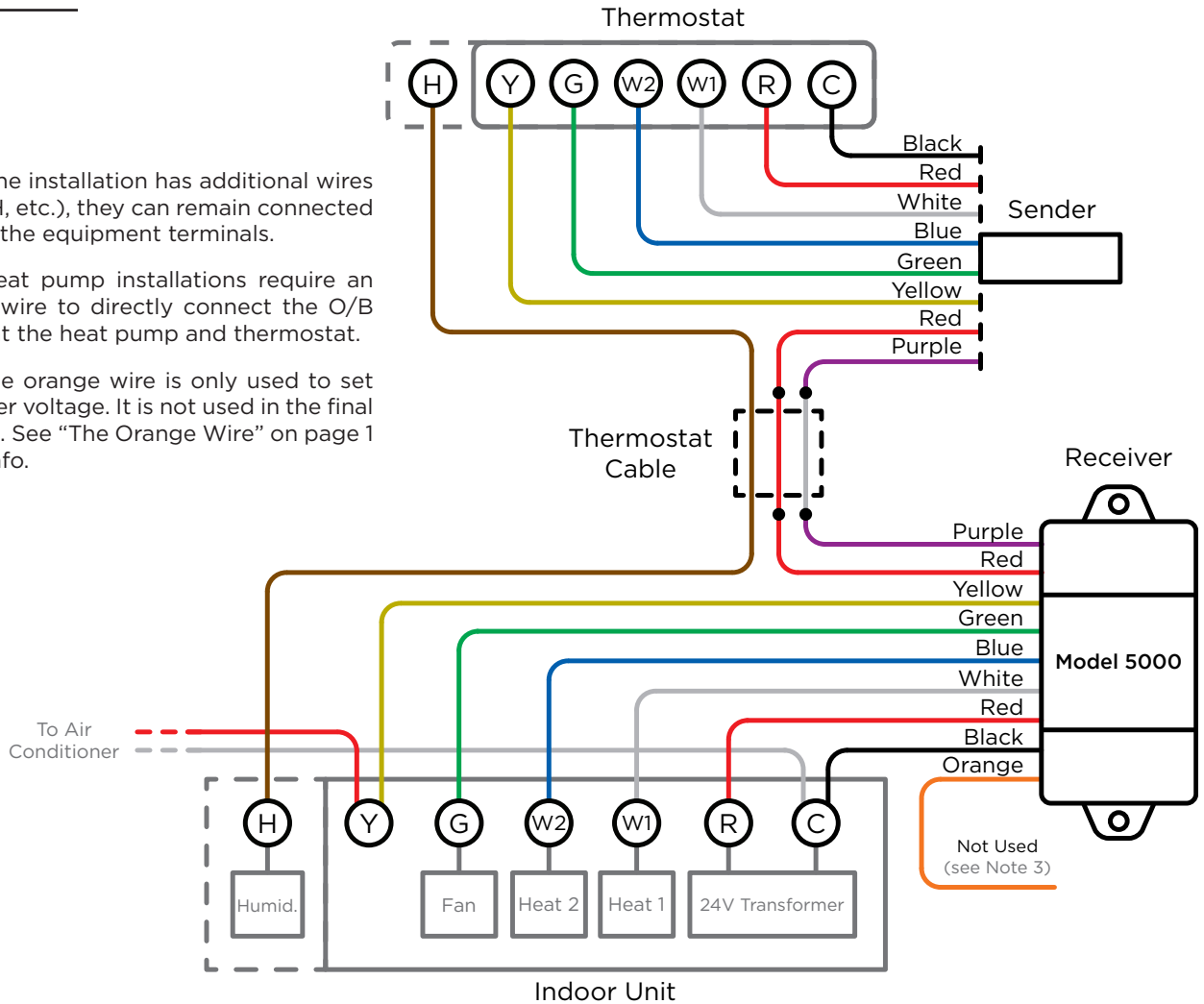

Note 1: If the installation has additional wires (Y2, O/B, H, etc.), they can remain connected directly to the equipment terminals.

Note 2: Heat pump installations require an additional wire to directly connect the O/B terminals at the heat pump and thermostat.

Note 3: The orange wire is only used to set the Receiver voltage. It is not used in the final installation. See "The Orange Wire" on page 1 for more info.

B Dry-Contact Heating System

Before

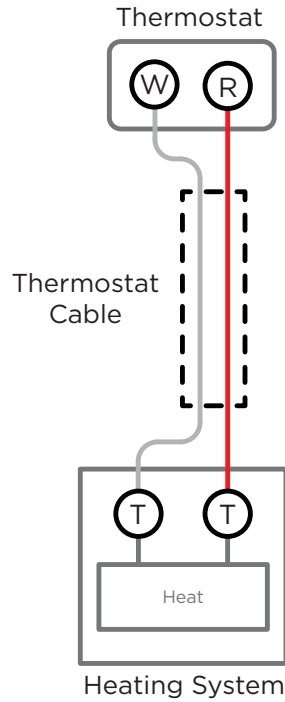

After

Note 1: A 24VAC relay will have to be installed to provide electrical isolation between the two systems.

Note 2: The blue wire on both the Sender and Receiver should be taped back as they will not be used.

Note 3: The orange wire is only used to set the Receiver voltage. It is not used in the final installation. See "The Orange Wire" on page 1 for more info.

